

Sonderdiamantschleifer / Electroplated spiral diamond finishers

Körnung / grit size
ISO 544
ISO-Nr.
806 104 ...

Figur-Nr. / Shape #
ø 1/10 mm
VE / packaging unit

Order-Nr.

extragrob, schwarzer Ring / extracoarse, black ring

<p>LÖFFELRANDSCHLEIFER PERIPHERY FINISHER</p> <p>— 060 1</p> <p>60016</p> <p>●</p>	<p>ALVEOLARSCHLEIFER ALVEOLAR FINISHER</p> <p>— 060 1</p> <p>60015</p> <p>●</p>
---	--

5' - 15000 Upm/rpm

Anwendung/Application



- Kunststoffe
Acrylics
- Lichthärtende Löffelmaterialien
Light curing tray materials

Körnung / grit size
ISO 544
ISO-Nr.
806 104 ...

Figur-Nr. / Shape #
ø 1/10 mm
VE / packaging unit

Order-Nr.

extragrob, schwarzer Ring / extracoarse, black ring

--	--	--

PINFIX

5' - 15000 Upm/rpm

490
053
1

60017

●

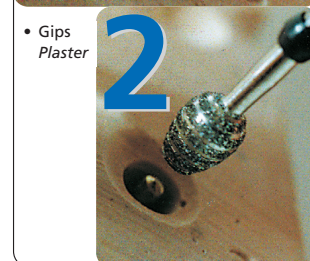
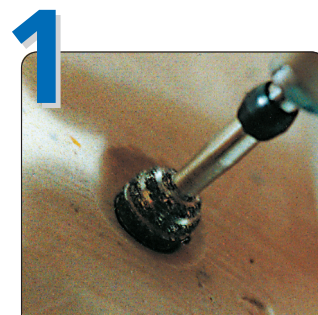

- Gips
Plaster

Sonderdiamantschleifer / Electroplated spiral diamond finishers

Körnung / grit size
ISO 544
ISO-Nr.
806 104 ...
 Figur-Nr. / Shape #
 ø 1/10 mm
 VE / packaging unit

extragrob, schwarzer Ring / extracoarse, black ring

	MINI	PLASTURBO	MAXI
		5' - 10000 Upm/rpm	
Figur-Nr. / Shape #	001		001
ø 1/10 mm	025		035
VE / packaging unit	1		1

Order-Nr. 60028 60029

Anwendung/Application

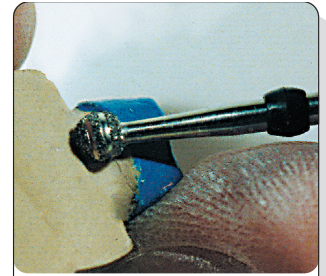

- **MINI** -> Zum zirkulären, schmierfreien Beschleifen der marginalen Präparationsstufe bei Frontstümpfen
 -> For grinding at the marginal line of incisive dies
- **MAXI** -> Zum zirkulären, schmierfreien Beschleifen der Molarenstümpfe
 -> For grinding at the surface of molar dies

Körnung / grit size
ISO 544
ISO-Nr.
806 104 ...
 Figur-Nr. / Shape #
 ø 1/10 mm
 VE / packaging unit

extragrob, schwarzer Ring / extracoarse, black ring

GUSSKANALSCHLEIFER / SPRUE FINISHER
 10' - 20000 Upm/rpm

Figur-Nr. / Shape #	076
ø 1/10 mm	130
VE / packaging unit	1

Order-Nr. 60052



- Co-Cr Legierungen
 Cobalt chrome alloys
- NE Legierungen
 Non-precious alloys

Körnung / grit size
ISO 544
ISO-Nr.
806 104 ...
 Figur-Nr. / Shape #
 ø 1/10 mm
 VE / packaging unit

extragrob, schwarzer Ring / extracoarse, black ring

TURBO DIAMANTSCHLEIFER / TURBO DIAMOND GRINDERS
 3' - 15000 Upm/rpm

Figur-Nr. / Shape #	200	200	200	201	237	274	291
ø 1/10 mm	027	043	063	027	063	063	027
VE / packaging unit	1	1	1	1	1	1	1

Order-Nr. 60022 60020 60024 60023 60027 60025 60021



- Ideal für weichbleibende Unterfütterungsmaterialien
 Ideal for soft relining materials
- Alle Kunststoffe
 All acrylics
- Gips
 Plaster
- Lichthärtendes Löffelmaterial
 Light curing tray material

Galvanische Diamantschleifer HST / Electroplated HP diamonds

Körnung / grit size
ISO 514 fein/fine
524 mittel/medium
544 extragrob/extracoarse
ISO-Nr.
806 104 ...
 Figur-Nr. / Shape #
 ø 1/10 mm
 KL/head length
 VE / packaging unit

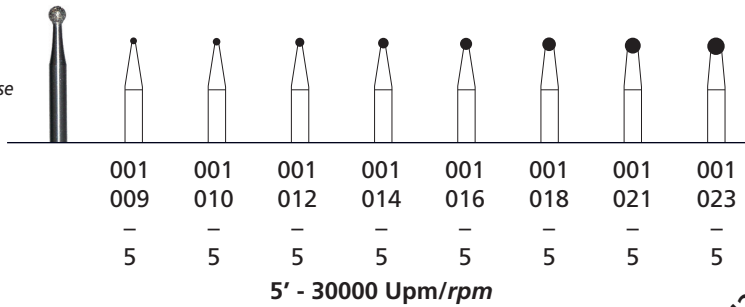

Order-Nr.

60001098 ●
 60001108 ●
 60001128 ●
 60001148 ●
 60001168 ●
 60001163 ●
 60001188 ●
 60001218 ●
 60001236 ●
 60001238 ●

Anwendung/Application

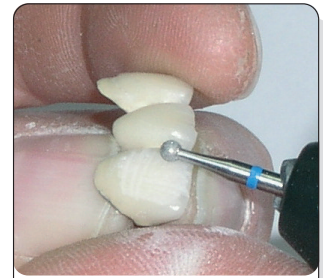

- Keramik
Ceramics
- Harte Komposite
Hard composites

Körnung / grit size
ISO 524 mittel/medium
ISO-Nr.
806 104 ...
 Figur-Nr. / Shape #
 ø 1/10 mm
 KL/head length
 VE / packaging unit

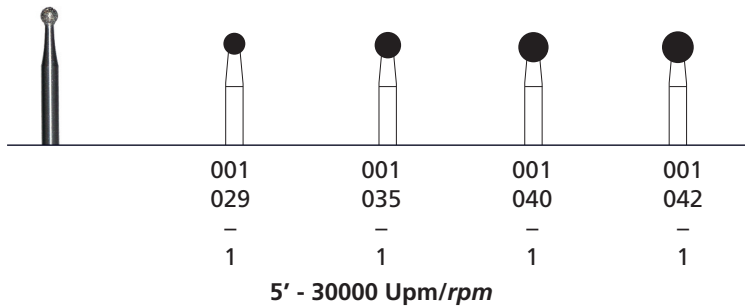

Order-Nr.

60001298 ●
 60001358 ●
 60001408 ●
 60001428 ●

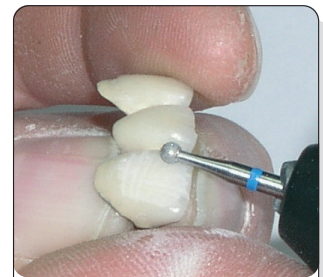

- Keramik
Ceramics
- Harte Komposite
Hard composites

Körnung / grit size
ISO 524 mittel/medium
ISO-Nr.
806 104 ...
 Figur-Nr. / Shape #
 ø 1/10 mm
 KL/head length
 VE / packaging unit

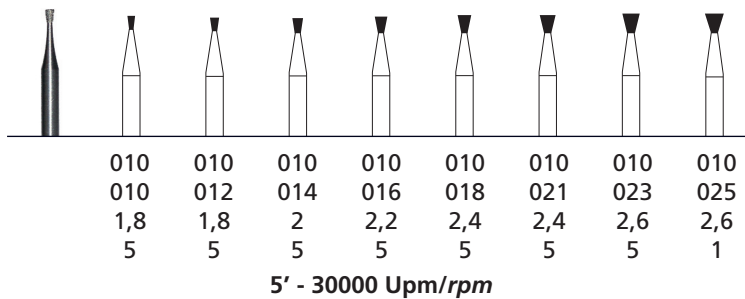

Order-Nr.

60010108 ●
 60010128 ●
 60010148 ●
 60010168 ●
 60010188 ●
 60010218 ●
 60010238 ●
 60010258 ●



- Keramik
Ceramics
- Harte Komposite
Hard composites

Galvanische Diamantschleifer HST / Electroplated HP diamonds

Körnung / grit size
ISO **524** mittel/medium

ISO-Nr.
806 104 ...

Figur-Nr./Shape #
ø 1/10 mm
KL/head length
VE / packaging unit

013	060	023	040	045
3,4	0,8	1,4	1,5	
1	5	1	1	

5' - 30000 Upm/rpm

Order-Nr.

60013608
60014238
60014408
60014458

Anwendung/Application

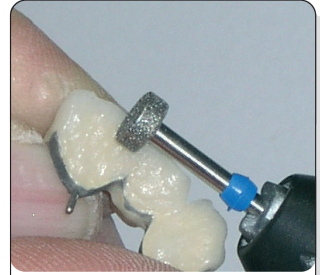

- Keramik
Ceramics
- Harte Komposite
Hard composites

Körnung / grit size
ISO **524** mittel/medium

ISO-Nr.
806 104 ...

Figur-Nr./Shape #
ø 1/10 mm
KL/head length
VE / packaging unit

040	040	041	042
033	040	050	060
1	1	1,1	2,6
1	1	1	1

5' - 30000 Upm/rpm

Order-Nr.

60040338
60040408
60041508
60042608

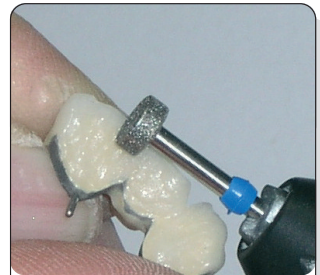

- Keramik
Ceramics
- Harte Komposite
Hard composites

Körnung / grit size
ISO **524** mittel/medium

ISO-Nr.
806 104 ...

Figur-Nr./Shape #
ø 1/10 mm
KL/head length
VE / packaging unit

068	109	109	109
055	010	012	016
2,1	4	4	4,5
1	5	5	5

5' - 30000 Upm/rpm

Order-Nr.

60068558
60109108
60109128
60109168



- Keramik
Ceramics
- Harte Komposite
Hard composites

Galvanische Diamantschleifer HST / Electroplated HP diamonds

Körnung / grit size
 ISO **524** mittel/medium
534 grob/coarse
 ISO-Nr.
806 104 ...
 Figur-Nr. / Shape #
 ø 1/10 mm
 KL/head length
 VE / packaging unit

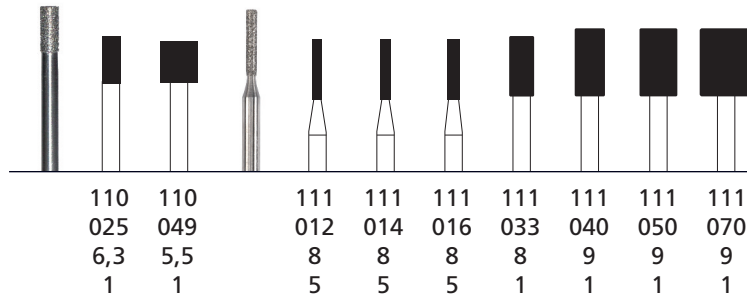

5' - 30000 Upm/rpm

- 60110258
- 60110498
- 60110495
- 60111128
- 60111148
- 60111168
- 60111338
- 60111408
- 60111508
- 60111708

Order-Nr.

Anwendung/Application



- Keramik
Ceramics
- Harte Komposite
Hard composites

Körnung / grit size
 ISO **514** fein/fine
524 mittel/medium
534 grob/coarse
 ISO-Nr.
806 104 ...
 Figur-Nr. / Shape #
 ø 1/10 mm
 KL/head length
 VE / packaging unit

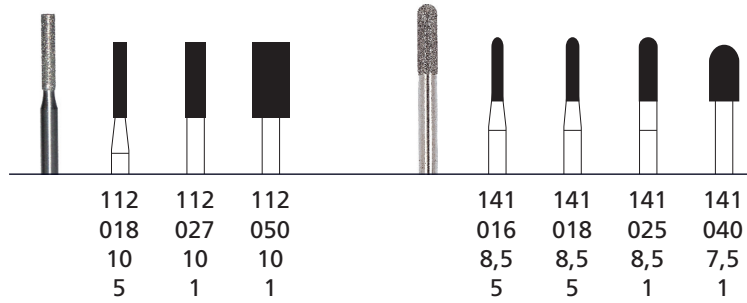

5' - 30000 Upm/rpm

- 60112186
- 60112188
- 60112276
- 60112278
- 60112508
- 60141168
- 60141188
- 60141185
- 60141256
- 60141258
- 60141408

Order-Nr.



- Keramik
Ceramics
- Harte Komposite
Hard composites

Körnung / grit size
 ISO **524** mittel/medium
534 grob/coarse
544 extragrob/extracoarse
 ISO-Nr.
806 104 ...
 Figur-Nr. / Shape #
 ø 1/10 mm
 KL/head length
 VE / packaging unit

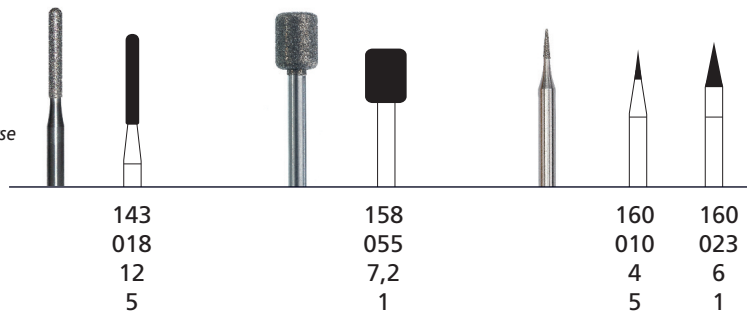

5' - 30000 Upm/rpm

- 60143188
- 60143183
- 60158558
- 60158555
- 60160108
- 60160238

Order-Nr.

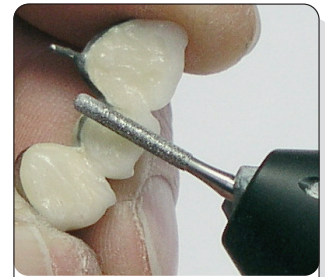

- Keramik
Ceramics
- Harte Komposite
Hard composites

- Schwarz / Black
- Co-Cr-Legierungen
Co-Cr alloys

Galvanische Diamantschleifer HST / Electroplated HP diamonds

Körnung / grit size
 ISO **514** fein/fine
524 mittel/medium
 ISO-Nr.
806 104 ...
 Figur-Nr. / Shape #
 ø 1/10 mm
 KL/head length
 VE / packaging unit

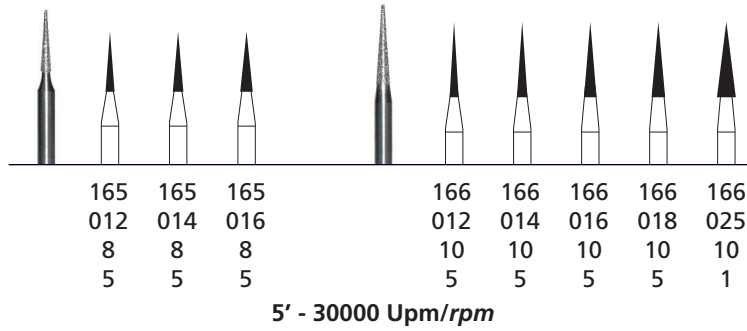

Order-Nr.

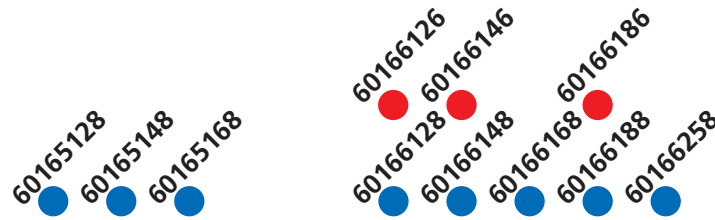

Anwendung/Application



- Keramik
Ceramics
- Harte Komposite
Hard composites

Körnung / grit size
 ISO **514** fein/fine
524 mittel/medium
 ISO-Nr.
806 104 ...
 Figur-Nr. / Shape #
 ø 1/10 mm
 KL/head length
 VE / packaging unit

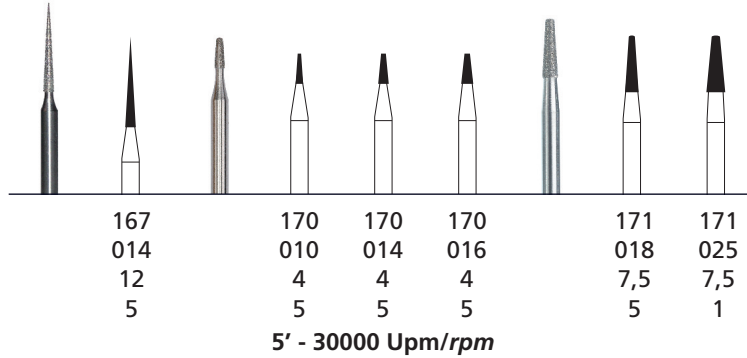

Order-Nr.

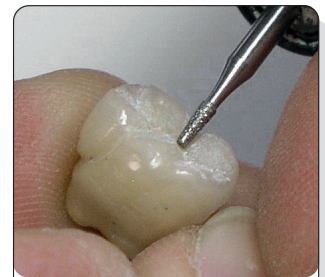
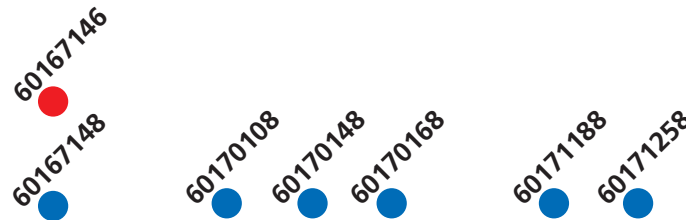

- Keramik
Ceramics
- Harte Komposite
Hard composites

Körnung / grit size
 ISO **514** fein/fine
524 mittel/medium
534 grob/coarse
544 extragrob/extracoarse
 ISO-Nr.
806 104 ...
 Figur-Nr. / Shape #
 ø 1/10 mm
 KL/head length
 VE / packaging unit

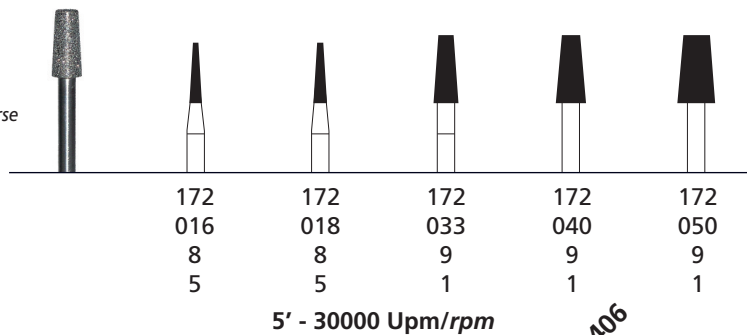

Order-Nr.

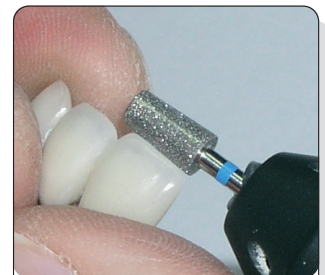
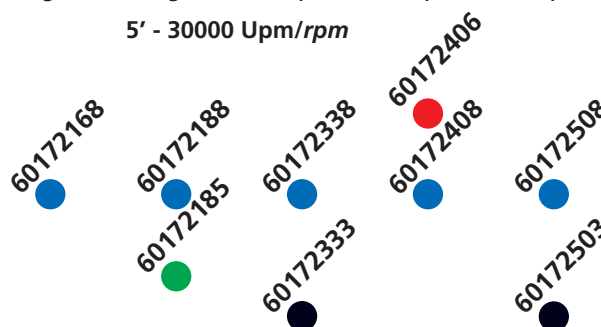

- Keramik
Ceramics
- Harte Komposite
Hard composites

Schwarz / Black
 • Co-Cr-Legierungen
Co-Cr alloys

Galvanische Diamantschleifer HST / Electroplated HP diamonds

Körnung / grit size
 ISO **514** fein/fine
524 mittel/medium
534 grob/coarse
 ISO-Nr.
806 104 ...
 Figur-Nr. / Shape #
 ø 1/10 mm
 KL/head length
 VE / packaging unit

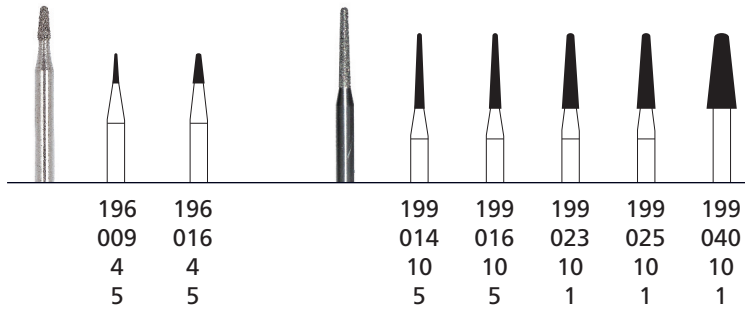

5' - 30000 Upm/rpm

Order-Nr.

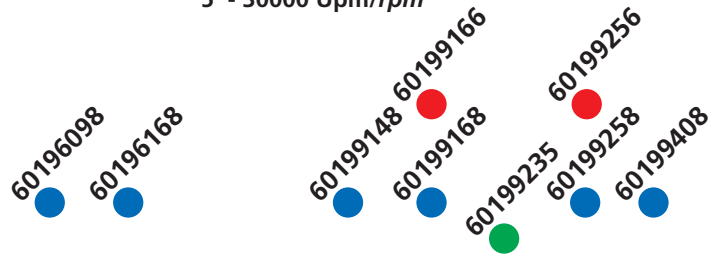

Anwendung/Application



- Keramik
Ceramics
- Harte Komposite
Hard composites

Körnung / grit size
 ISO **514** fein/fine
524 mittel/medium
 ISO-Nr.
806 104 ...
 Figur-Nr. / Shape #
 ø 1/10 mm
 KL/head length
 VE / packaging unit

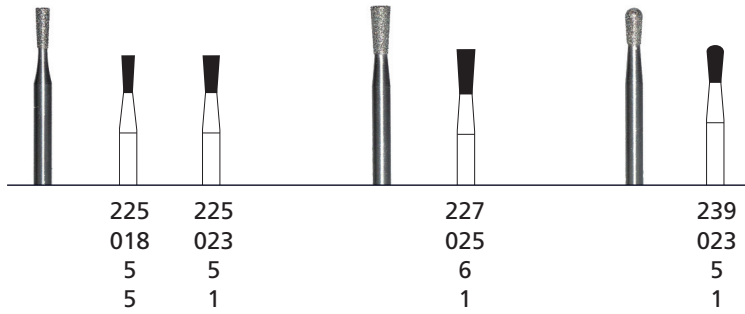

5' - 30000 Upm/rpm

Order-Nr.

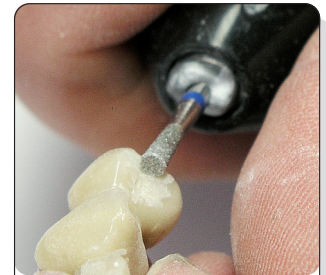
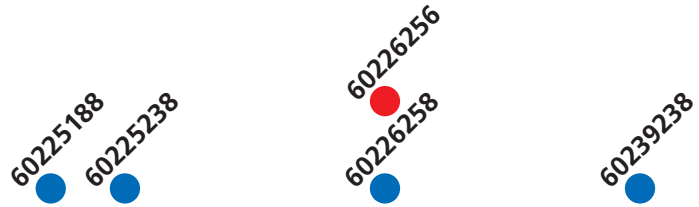

- Keramik
Ceramics
- Harte Komposite
Hard composites

Körnung / grit size
 ISO **514** fein/fine
524 mittel/medium
 ISO-Nr.
806 104 ...
 Figur-Nr. / Shape #
 ø 1/10 mm
 KL/head length
 VE / packaging unit

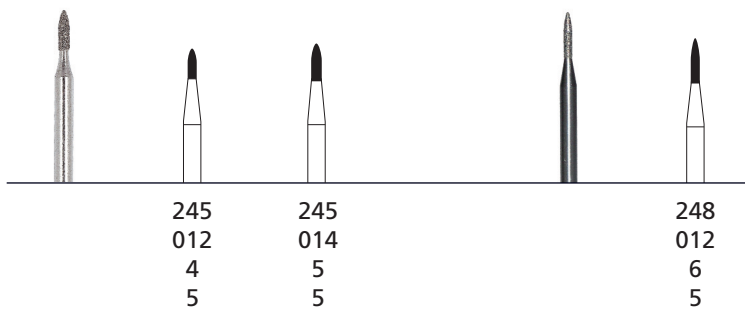

5' - 30000 Upm/rpm

Order-Nr.



- Keramik
Ceramics
- Harte Komposite
Hard composites

Galvanische Diamantschleifer HST / Electroplated HP diamonds

Körnung / grit size
 ISO **514** fein/fine
524 mittel/medium
544 extragrob/extracoarse
 ISO-Nr.
806 104 ...
 Figur-Nr. / Shape #
 ø 1/10 mm
 KL/head length
 VE / packaging unit

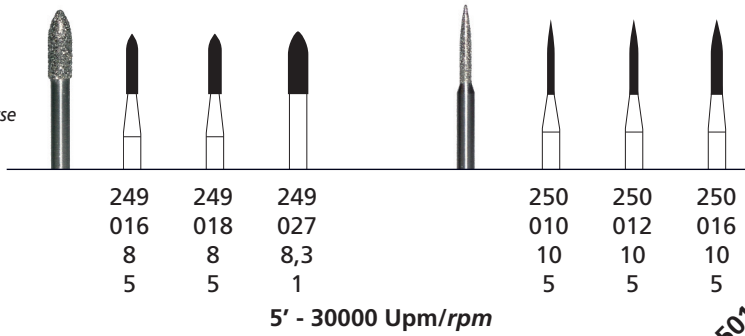

Order-Nr.

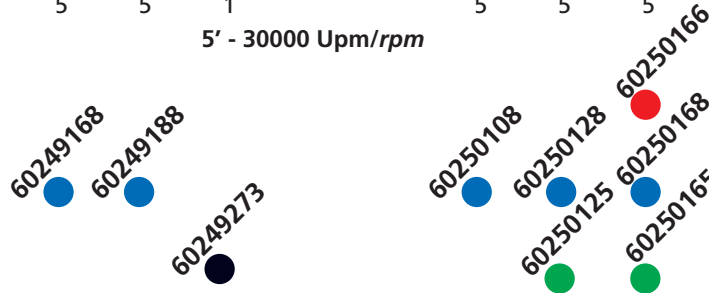

Anwendung/Application



- Keramik
Ceramics
 - Harte Komposite
Hard composites
- Schwarz / Black
- Co-Cr-Legierungen
Co-Cr alloys

Körnung / grit size
 ISO **514** fein/fine
524 mittel/medium
534 grob/coarse
 ISO-Nr.
806 104 ...
 Figur-Nr. / Shape #
 ø 1/10 mm
 KL/head length
 VE / packaging unit

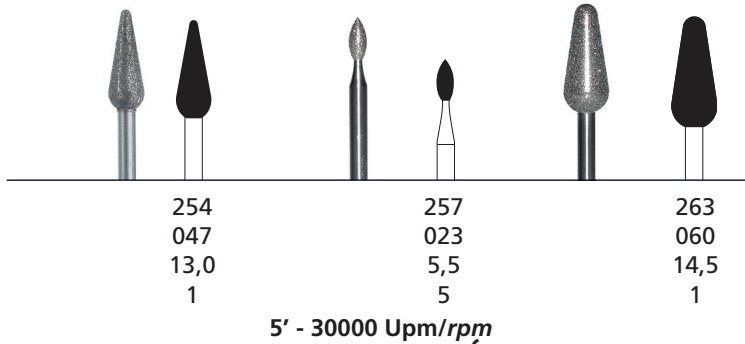

Order-Nr.

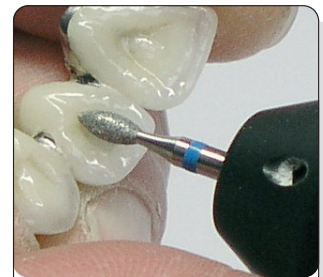
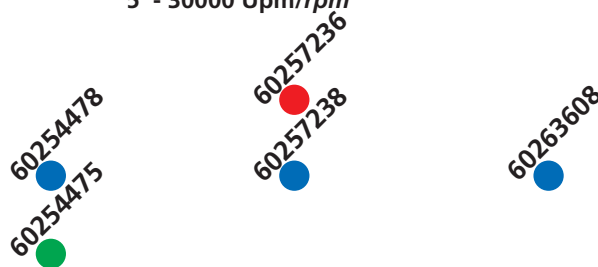

- Keramik
Ceramics
 - Harte Komposite
Hard composites
- Schwarz / Black
- Co-Cr-Legierungen
Co-Cr alloys

Körnung / grit size
 ISO **514** fein/fine
524 mittel/medium
544 extragrob/extracoarse
 ISO-Nr.
806 104 ...
 Figur-Nr. / Shape #
 ø 1/10 mm
 KL/head length
 VE / packaging unit

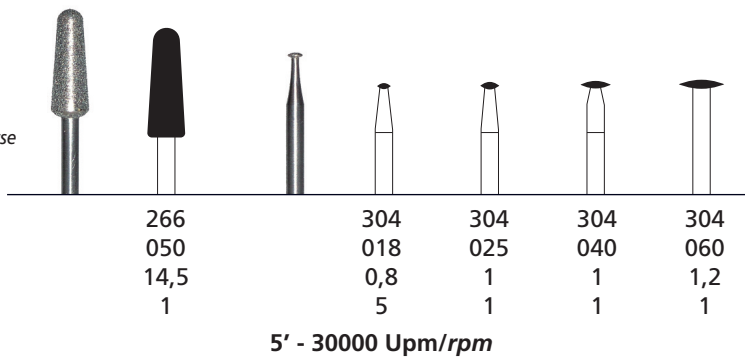

Order-Nr.

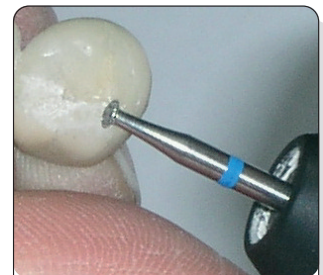
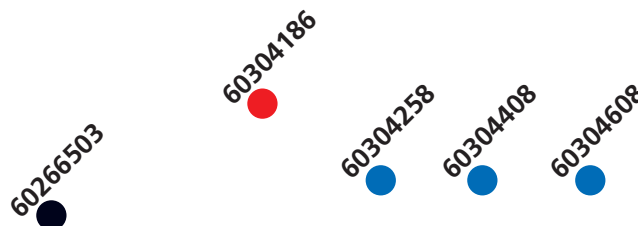

- Keramik
Ceramics
 - Harte Komposite
Hard composites
- Schwarz / Black
- Co-Cr-Legierungen
Co-Cr alloys

Galvanische Diamantschleifer HST / *Electroplated HP diamonds*

Körnung / grit size
 ISO **514** fein/fine
524 mittel/medium
 ISO-Nr.
806 104 ...
 Figur-Nr. / Shape #
 ø 1/10 mm
 KL/head length
 VE / packaging unit

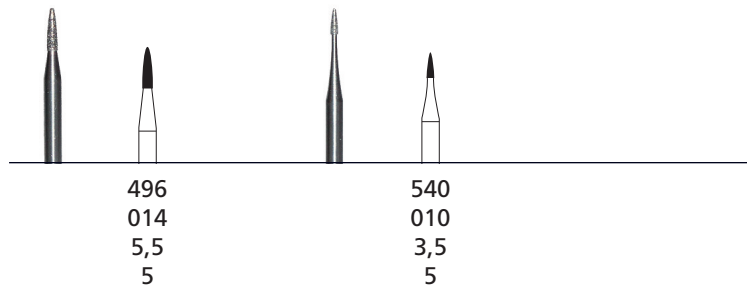

5' - 30000 Upm/rpm

60496146

 60496148

60540108

Order-Nr.

Anwendung/Application

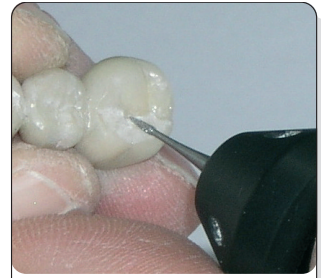

- Keramik
 Ceramics
- Harte Komposite
 Hard composites

Keramikdiamanten XL HST in verdichteter Diamantierung / *Electroplated HP diamonds XL in reinforced dense diamond coating*

Körnung / grit size
 ISO **524** mittel/medium
 ISO-Nr.
806 104 ...
 Figur-Nr. / Shape #
 ø 1/10 mm
 KL/head length
 VE / packaging unit

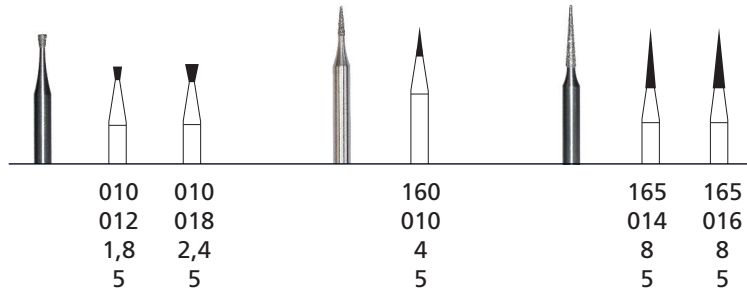

5' - 30000 Upm/rpm

600101295

 600101895

601601095

601651495

 601651695

Order-Nr.



- Keramik
 Ceramics
- Harte Komposite
 Hard composites

Körnung / grit size
 ISO **524** mittel/medium
 ISO-Nr.
806 104 ...
 Figur-Nr. / Shape #
 ø 1/10 mm
 KL/head length
 VE / packaging unit

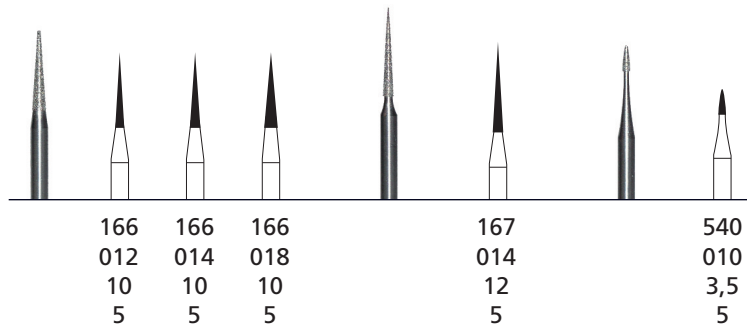

5' - 30000 Upm/rpm

601661295

 601661495

 601661895

601671495

605401095

Order-Nr.



- Keramik
 Ceramics
- Harte Komposite
 Hard composites